

Pharmacon Dispensing Robot in Pharmacy

^[1]M. Sathiyapriya, ^[2]R. Anitha, ^[3]M. Surendiran, ^[4]K. Meyvel, ^[5]L. Manivannan

^[1] ^[2] ^[3] ^[4] UG Student Knowledge Institute of Technology, Salem-637504

^[5] Assistant professor Knowledge Institute of Technology, Salem-637504

Abstract: Medical shops are playing a vital role in human health care system now a day. The customers are getting struggled while buying the medicines in the medical shop when it is more crowded. This leads to a very big issue for the supplier in providing the medicines to the customers at right time and as well during emergency period. The proposed system introduces an autonomous robot which itself picks up the medicine from the storage area and drops it into the dispenser box without any human intervention. It overcomes the difficulties of existing system done by manually.

Keywords: ATMEGA 2650 Fire Bird V Kit Robot, Pick and Place, Arm.

I. INTRODUCTION

The present scenario like increase in pollution, improper food habit etc. makes people become sick. This leads to increase in the number of people visiting the hospitals daily. The number of hospitals and medical shops in the country is also increasing day by day. In hospitals and medical shops, medicine dispensing systems play an important role by providing right medicines at right time. The traditional medicine dispensing system is now unreliable and takes too much of time to dispatch the medicines to the customers. This makes the customer to wait in a long queue and feel uncomfortable. Especially this condition has to be avoided for the customers who are coming under emergency situation. But our traditional system fails to do so. Hence the proposed novel system with an autonomous robot takes less time in finding the medicine in the storage area and dispatches the same to the customer as fast as possible. This makes our medical shops become smart, reliable and keeps customer to feel comfortable.

II. LITERATURE SURVEY

^[1] Design and Analysis of Intelligent Robotic Arm. Rishi kanth, A. Srinath describes the idea behind this work is to reduce the utilization of human energy for hazardous applications. This work involves in development of pneumatic controlled pick and place arm. To achieve this goal we intend to incorporate a simple linkage actuation mechanism. An AC motor is used along with spur gears and a threaded shaft arrangement. The gripper can perform the basic function of picking, holding and grasping of objects by means of a DC motor and it forms the mechanism. This work gives details about how to design and assemble the pneumatic pick and place robotic arm and analyze the design for better material properties to bare the maximum load conditions. The gripper can easily accessible for any design of components without slipping.

^[2] Android Based Robot Implementation For Pick and Retain of Objects. Ranjith Kumar Goud, B.Santhosh Kumar describes the project they can diffuse the bomb from safe distance and it can save more lives. We can send the few commands to the robot situated at the bomb. We can control two motors situated at the wheels for direction control and other two motors at robot hand. With these four motors we can control all the directions of the robot and at the same time we can pick any object at any direction. After our robot is in position we have move the robotic arm which is placed above the robot. After deciding to cut wire of bomb we need to move robot jaws and arm. Jaws are used to move arm up or down. One motor is dedicated to control the jaw moment. Other motor is used to control the arm. This is used to tighten the grip or losing the grip. If we are unable to cut the wire or so we can directly move the bomb to the safe sight.

^[3] Pick and Place Robotic Arm Implementation Using Arduino. Ashly Baby, ChinnuAugustidescribes the paper that a robotic arm is designed using arduino to pick and place the objects via user commands. It will pick and place an object from source to destination safely. The soft catching gripper used in the arm will not apply any extra pressure on the objects. The robot is controlled using android based smart phones through Bluetooth. Based on the commands given by the user the robot moves

accordingly. At the receiver end there are four motors interfaced with the micro controller. Two for the vehicle movement and the remaining two are for arm and gripper movement. Blue control application is used for the controlling of robot.

III. Existing Method

From literature survey the projects are only focus on the military application like diffusing bomb and human hazardous applications. Since now robot arm is not use in medical field. In the medical field, human's provide the tablet to the costumer. It takes a long time. Delivering the medicines to the customers at the right time and during emergency period without delay. Eradicate the human errors and to improve the crowd management during peak hours.

IV. PROPOSED METHOD

In Medical shop initially the medicine boxes barcode are scanned by the barcode reader and details like medicine name, common name, manufacturer name, manufacturing date and expiry date etc. are entered in the personal computer. After entering the details of medicines in the pc, it is arranged alphabetically in the storage area manually. Numbering systems are also used in the medicine boxes to store the medicines and it is placed in the storage area. At the time of Customer ordered medicine, the shop keeper searches the medicine by entering the medicine name in the PC. It shows where that medicine is arranged in the storage area. This leads to increase in time to access the medicine in the storage area. We propose an idea for get the medicine tablets in storage area by using Firebird V platform robot with ATMEGA 2560 Controller and Movable Arm step with gripper arrangement. The position of tablet will identified by the using of barcode sensor and after identification of position of tablet it is picked by using Movable Arm step with gripper arrangement which is used to pick up the medicine box from the storage area and also to drop the medicine in the dispenser box.

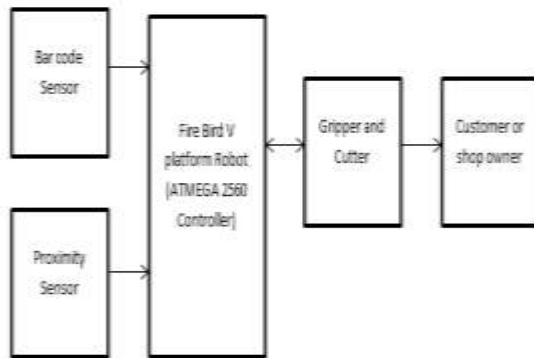

Fig.1 Block Diagram

Atmega 2560

The high-performance, low-power Microchip 8-bit AVR RISC-based microcontroller combines 256KB ISP flash memory, 8KB SRAM, 4KB EEPROM, 86 general purpose I/O lines, 32 general purpose working registers, real time counter, six flexible timer/counters with compare modes, PWM, 4 USARTs, byte oriented 2-wire serial interface, 16-channel 10-bit A/D converter, and a JTAG interface for on-chip debugging. The device achieves a throughput of 16 MIPS at 16 MHz and

operates between 4.5-5.5 volts. By executing powerful instructions in a single clock cycle, the device achieves a throughput approaching 1 MIPS per Hz balancing power consumption and processing speed.



Fig. 2 ATMEGA 2560 Controller

V. FIRE BIRD

It contains Smart NiMH battery charger with power adaptor, Serial cable, SB cable, Flex printed 6 feet white lineUSB Programmer (ISP). Specifications of Fire bird V robot is Atmel ATMEGA2560 as Master microcontroller, Atmel ATMEGA8 as Slave microcontroller, 2 x 16 Characters LCD, Indicator LEDs, Buzzer, Eight analog IR proximity sensors, Three white line sensors



Fig.3 Fire Bird V

Proximity sensor

A proximity sensor is a sensor able to detect the presence of nearby objects without any physical contact. A proximity sensor often emits an electromagnetic field or a beam of electromagnetic radiation (infrared, for instance), and looks for changes in the field or return signal. The object being sensed is often referred to as the proximity sensor's target. Different proximity sensor targets demand different sensors. For example, a capacitive proximity sensor or photoelectric sensor might be suitable for a plastic target; an inductive proximity sensor always requires a metal target.



Fig. 4 Proximity sensor

Servo Motor

A servomotor is a rotary actuator or linear actuator that allows for precise control of angular or linear position, velocity and acceleration. It consists of a suitable motor coupled to a sensor for position feedback. It also requires a relatively sophisticated controller, often a dedicated module designed specifically for use with servomotors. Servomotors are not a specific class of motor although the term servomotor is often used to refer to a motor suitable for use in a closed-loop system. Servomotors are used in applications such as robotics, CNC machinery or automated manufacturing.



Fig. 5 Servo Motor

Buzzer

A **buzzer** or **beeper** is an audio signaling device which may be mechanical, electromechanical, or piezoelectric. Typical uses of buzzers and beepers include alarm devices, timers, and confirmation of user input such as a mouse click or keystroke.



Fig. 6 Buzzer

Gripper

A gripper is a device which enables the holding of an object to be manipulated. The easier way to describe a gripper is to think of the human hand. Just like a hand, a gripper enables holding, tightening, handling and releasing of an object. A gripper is just one component of an automated system. A gripper can be attached to a robot or it can be part of a fixed

automation system. Many styles and sizes of grippers exist so that the correct model can be selected for the application. Compressed air is supplied to the cylinder of the gripper body forcing the piston up and down, which through a mechanical linkage, forces the gripper jaws open and closed. There are 3 primary motions of the gripper jaws; parallel, angular and toggle. These operating principals refer to the motion of the gripper jaws in relation to the gripper body.



Fig. 7 Gripper

CONCLUSION

The proposed system can be effectively utilized to dispatch the medicine to the inpatients of the hospitals. When the requirements of the inpatients given by the doctors can be directly cannot to the robot which will reduce the waiting time of inpatients unnecessarily along with outpatients. Also this will reduce the crowd in the medical shops at a time. An another robot can be implemented to pick up the medicine in the dispenser box after dispatch and can be placed in the respective cell of the medicine to reduce the manual work. The proposed system is suitable for all kind of medical shop weather retail or whole sale. It is cost effective solution to manage inadequacy of skilled labors and for proper functioning at all times.

REFERENCES

- [1] N. Rishi kanth, A. Srinath; "Design and Analysis of Intelligent Robotic Arm" International Journal of Scientific &Engineering Research Volume 8, Issue 12, December- 2017.
- [2] Ranjith Kumar Goud, B.Santhosh Kumar "Android Based Robot Implementation For Pick and Retain of Objects "International Journal of Enginnering Trends and Technology – Volume 16 November 3- Oct 2014.
- [3] Ashly Baby, Chinnu Augusti "Pick and Place Robotic Arm Implementation Using Arduino" IOSR Journal of Electrical and Electronics Engineering e- ISSN: 2278-1676, p- ISSN: 2320- 3331, Volume 12, Issue 2 Ver, III(Apr- 2017).
- [4] MR. Cohen (2002), "Medication Errors: Causes, prevention and risk management" Boston, MA: Jones and Bartlett Publishers.
- [5] Waitemata District Health Board (2006), "Finding Your Way through the Medication Administration Test", Auckland: Waitemata District Health Board.
- [6] Conrad C, Fields W, McNamara T, (2010), "Medication room madness: calming the chaos -Journal of Nursing 25(2): 137-44".

- [7] North West Melbourne Division of General Practice (2006),” *GP and Residential Aged CareKit-Melbourne*”, Vic: North West Melbourne Division of General Practice.
- [8] Reid-Searl K, Dwyer T, Ryan J, et al (2006),”*Student Nurse Survival Guide. Sydney, New South Wales*”: Pearson Education Australia.
- [9] Waitemata District Health Board (2010), “*Medicines Reconciliation E-template*”, Auckland: Waitemata District Health Board and Whitehead N (2009), “*Clinical Services Manual*”, Auckland: Simple Solutions Consultancy Ltd.
- [10] A guide to good practice in the management of controlled drugs in primary care (England). Second Edition Feb 2007 from the National Prescribing Centre (NPC).
- [11] World Health Organization Department of Essential Drugs and Medicines Policy (edm) ch-1211 Geneva 27-switzerland.
- [12] Health and Disability Sector Standards 2008, NZS 8134:2008 and Ministry of Health.
- [13] Safe Management of Medicines: A guide for managers of old people’s homes and residential care facilities. Wellington: Ministry of Health.
- [14] North West Melbourne Division of General Practice. 2006. *GP and Residential Aged Care Kit*. Melbourne, Vic: North West Melbourne Division of General Practice.
- [15] Royal Australian and New Zealand College of Psychiatrists. 2008. *The Use of Antipsychotics in Residential Aged Care: Clinical recommendations developed by the RANZCP Faculty of Psychiatry of Old Age (New Zealand)*.